

# All-Vinyl Window Mull, Stack, or Mull & Stack Instructions

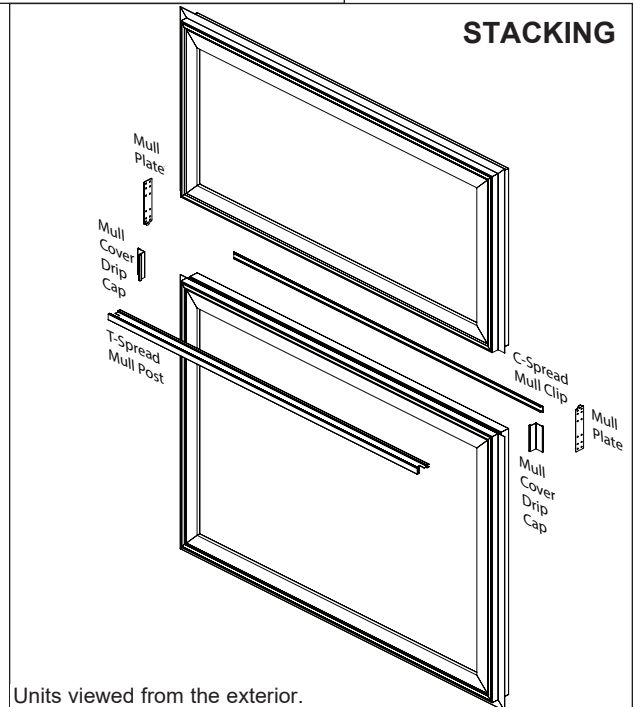
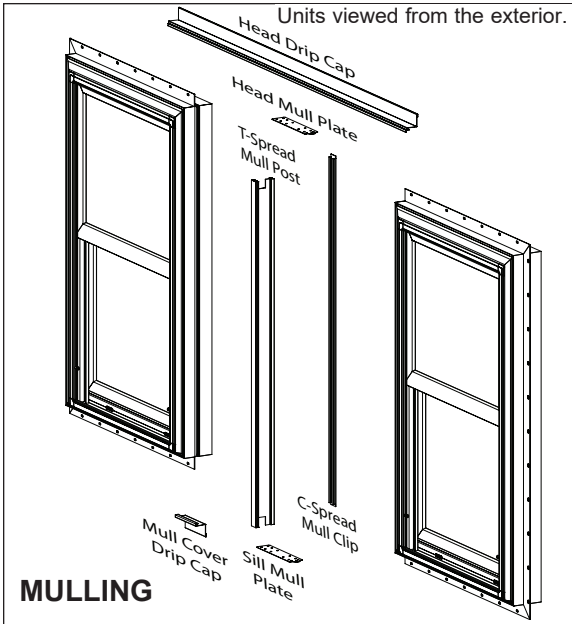

**IMPORTANT:** Please read before you begin.

**Table of Contents and Tool/Material Requirements**

**TABLE OF CONTENTS**

	<b>START PAGE</b>
<b>About Mulling, Stacking &amp; Mulling and Stacking</b> .....	2
<b>Safety Precautions</b> .....	3
<b>General Information</b> .....	4
<b>Mull and Stack Components</b> .....	5
<b>Unit Preparation</b> .....	6
Tin Snips, Locking Pliers, Utility Knife	
<b>Mull Clip and Mull Post Configuration</b> .....	7
<b>Measuring for Mull Clips and Mull Posts</b> .....	8
Tape Measure, Pencil, Paper to Record Measurements, Hack Saw, Utility Knife	
<b>Mull Clip Installation – Interior</b> .....	9
High Quality Clear Exterior Silicone Sealant, Caulking Gun, Utility Knife, End Nipper Pliers, Wood Block, Clean Soft Rags, Denatured Alcohol, Spray Bottle, Soft-Faced Hammer, Mull Clips, Foam Caulk Saver/Backer Rod	
<b>Mull Post Installation – Exterior</b> .....	10
High Quality Clear Exterior Silicone Sealant, Caulking Gun, Utility Knife, End Nipper Pliers, Wood Block, Clean Soft Rags, Denatured Alcohol, Spray Bottle, Soft-Faced Hammer, Mull Posts, Foam Caulk Saver/Backer Rod	
<b>Apply Joining Plates; Install Plumb Plates – Optional Procedure</b> .....	14
Joining Plates, #8 x 1/2" Phillips Pan Head Stainless Steel Sheet Metal Screws, Power Drill with Screwdriver Bits	
<b>Install Head Drip Cap</b> .....	15
Matching Drip Cap, Silicone Sealant, Caulking Gun, Measuring Tape, Pencil, Utility Knife, End Nipper Pliers, Sill Gaskets, Foam Backer Rod	
<b>Seal Side and Sill Joints</b> .....	18
Matching Drip Cap, Silicone Sealant, Caulking Gun, Measuring Tape, Utility Knife, End Nipper Pliers	

## About Mulling, Stacking & Mulling and Stacking

### WARNING

Stacking, mulling, or combinations of stacking and mulling may have installation restrictions and require additional reinforcement in your area. The window manufacturer recommends that the installer consult a registered Architect or local Structural Engineer for guidance to ensure the installation meets all codes and rules regarding installation of mulled, stacked, or mulled and stacked combinations.

FIGURE 1

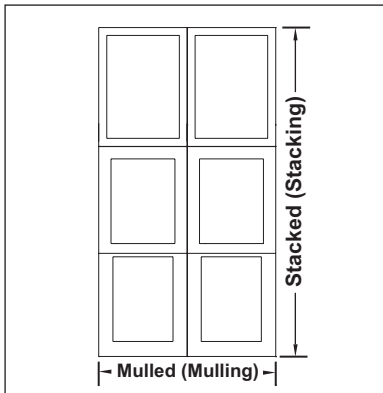

The process for mulling or stacking differs from mulling and stacking.

Please observe the following definitions for terms used in the subsequent instructions:

- **Mulled:** Joining two or more units together horizontally (FIGURE 1).
- **Stacked:** Joining two or more units together vertically (FIGURE 1).
- **Mulled and Stacked:** Joining three or more units together horizontally and vertically (FIGURE 1).

 **IMPORTANT:** Thoroughly read and follow these instructions. Failure to assemble as recommended will void any warranty, expressed or implied. **Check building codes for the area in which the windows are being installed before installation to ensure proper compliance.** The instructions that follow are based on typical frame construction. Specific applications may differ. The window manufacturer recommends that you consult a qualified installation professional. The window manufacturer is not responsible for installation.

Some local building codes may require the use of continuous head drip caps over mulled windows. Full length drip caps are available.

The following instructions are for assembling individual window units into a mulled, stacked, or mulled and stacked configuration prior to installation. To actually install the newly combined unit into a rough opening, follow the installation instructions packed with the individual windows.

# ALL-VINYL WINDOW – MULL, STACK OR MULL & STACK

## Safety Precautions

*Please note the following precautions for your safety and well being.*



Recognize this symbol. This is the Safety-Alert symbol. When you see this symbol be alert to the potential for personal injury or product damage.



### DANGER

Falling from window opening may result in serious injury or death. DO NOT leave openings unattended when children are present.



### DANGER

#### CUT HAZARD

- \*Non-safety Glass.
- \*May cause serious injuries if broken.
- \*Do not install where tempered safety glass is required.



### WARNING

Improper use of hand and power tools could result in personal injury and/or product damage. Follow equipment manufacturers' instructions for safe operation. Always wear safety glasses.



### WARNING

Weight of window and accessories will vary. Use a reasonable number of people with sufficient strength to lift, carry and install window unit(s) and accessories. Always consider site conditions and use appropriate techniques when installing.



### DANGER



Screen will not stop children, anyone or anything from falling out window.

Keep children and objects away from open windows.



### IMPORTANT

High-quality, exterior, neutral-cure, clear, silicone sealant (compatible with vinyl) is to be used for all procedures in the following instructions which call for caulking or sealant.

**General Information**

The following instructions are for completing a standard mull, stack, or mull and stack operation for vinyl windows.

These instructions are for most windows with or without an integral brickmould and/or J-Channel (**FIGURE 1**). Units may come with an optional J-Channel filler, however, mulling and stacking procedures are the same.

Contact your customer service representative for instructions for mull and mull stack operations on other unit types and configurations.

To install a combined unit, follow the installation instructions packed with the individual windows. This booklet does not contain unit installation instructions.

**FIGURE 1**

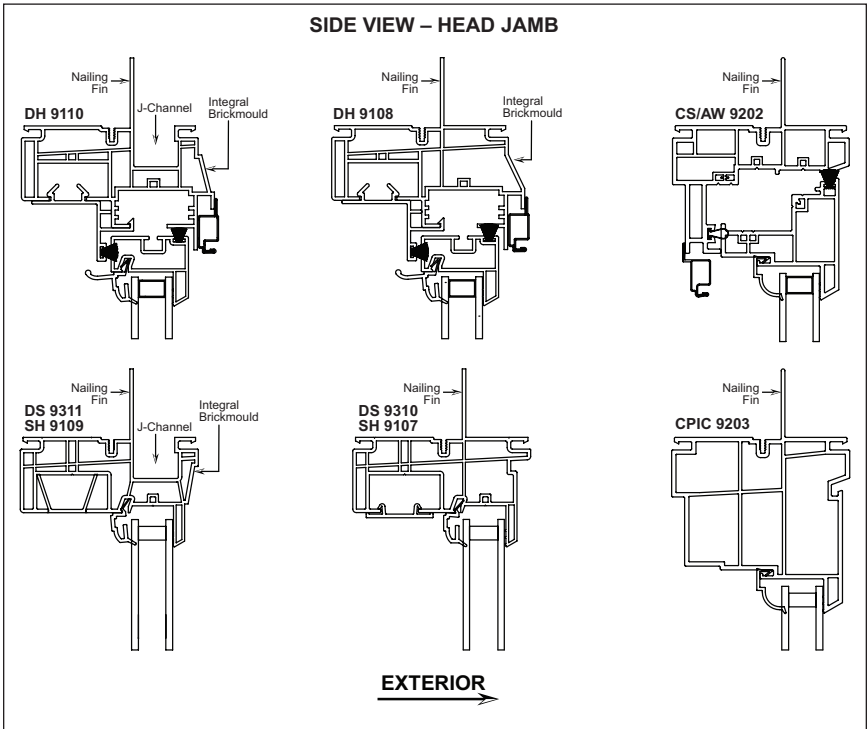

## Mull and Stack Components

Components to complete a mull and stack operation are shown in (FIGURE 1).

Each mull unit requires a full length head drip cap and a partial sill drip cap.

Stacked units require partial drip caps applied to the side jambs, where the units join.

Four-way mull and stack requires a full-length head drip cap, a partial sill drip cap, and side caps.

Mull - joining plates are used at mull and stack joints and are secured to the side jambs with #8 x 1/2" Phillips pan head stainless steel screws.

The self-adhesive gaskets are applied to the back side of the nailing fin to help seal the gap between adjacent nail fins. They should be applied to the head, sides and sill joints as appropriate.

The backer rods, if needed, are inserted 1/4" into the mull pocket on either side of the mull post. Any gaps are filled with silicone.

FIGURE 1

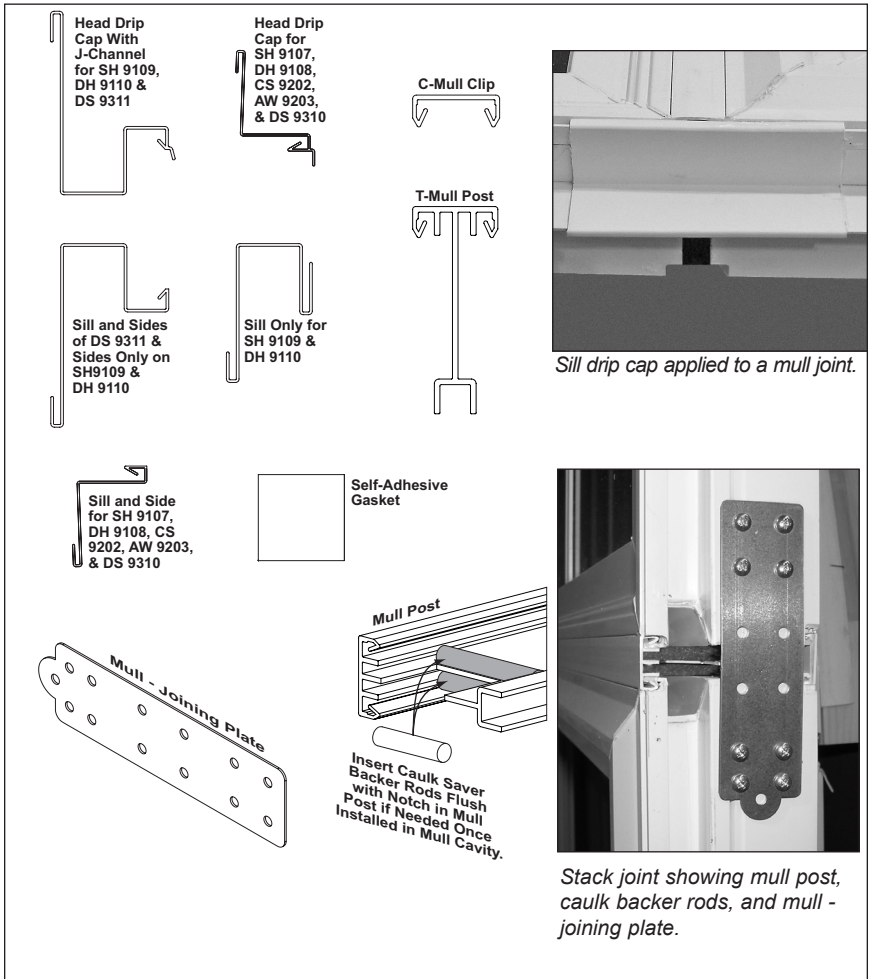

**Unit Preparation**

FIGURE 1

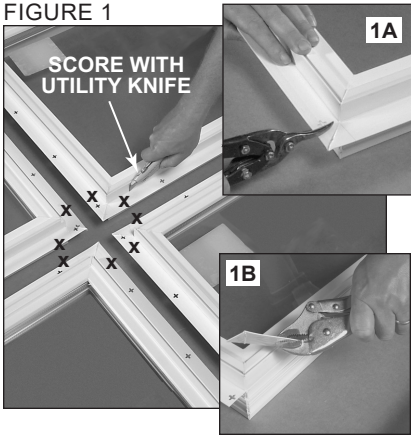

1. Remove all packaging and screens. Place units to be mullled and/or stacked on a clean flat surface (exterior facing up) in the position that they will be assembled (FIGURE 1).

**⚠ IMPORTANT:** Arrange individual units so the sills and or water weeps will all face the bottom of the rough opening when the newly combined unit is installed.

2. Nailing fins must be removed from jambs that will be attached together ('x's in FIGURE 1). Identify these fins and score each fin, next to the jamb, with a utility knife (FIGURE 1). Use a tin snips to make an initial cut into a fin (FIGURE 1A). Bend the fin, adjacent to this cut, up and down with locking pliers until it breaks off (FIGURE 1B). Continue this method until all identified fins are removed.

FIGURE 2

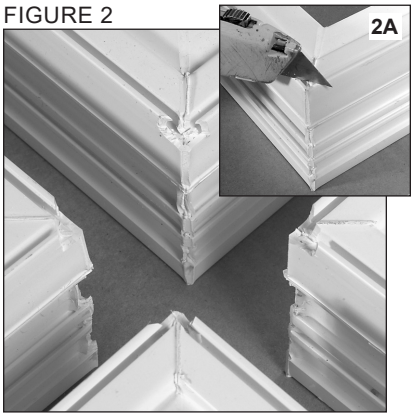

3. If you will be mulling and stacking, use a rotary tool or utility knife to open the exterior accessory groove corners so the mull strips can run the full length of the assembly (FIGURES 2 & 2A).

4. For mullled units, notch the head and sill exterior accessory grooves on adjoining units so the head and sill drip cap snap-in-legs will seat properly (FIGURE 3).

5. Turn individual units over and open the interior accessory groove corners, as in Step 3 above, for mull and stack.

FIGURE 3

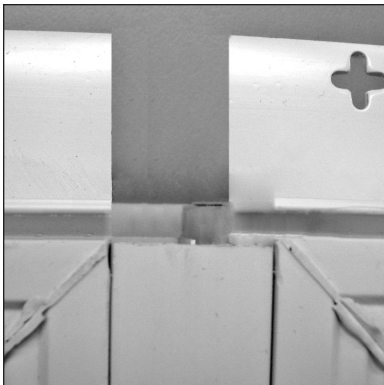

**Mull Clip and Mull Post Configuration**

**For Mullied Units:**

Mull connectors run the full height of the units (FIGURE 1).

FIGURE 1

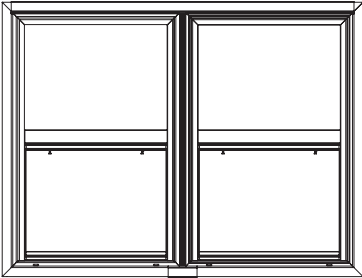

**For Stacked Units**

Mull connectors run the full width of the units (FIGURE 2).

FIGURE 2

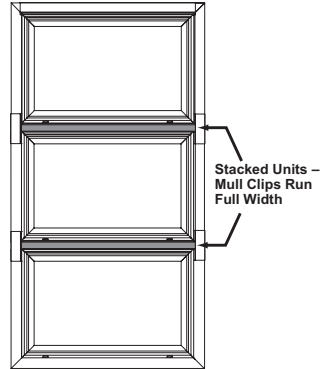

**NOTE:** Mull clips and mull posts should be arranged so they run the same direction on both interior and exterior.

**For A 3-Way Mull/Stack Combination**

The horizontal mull connectors install first and run the full width. The vertical connectors meet the horizontal pieces (FIGURE 3).

FIGURE 3

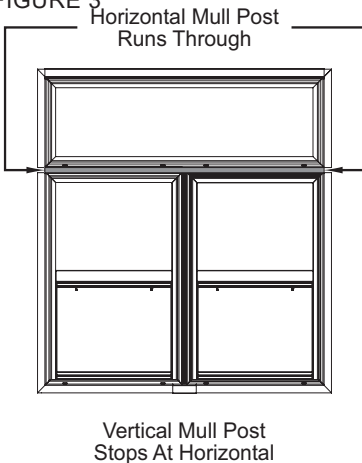

**4-Way Mull/Stack Combination**

Vertical mull connectors run the full height of the combined units and are installed first. Horizontal mull connectors meet at the vertical pieces and are cut to the width of each individual unit (FIGURE 4).

FIGURE 4

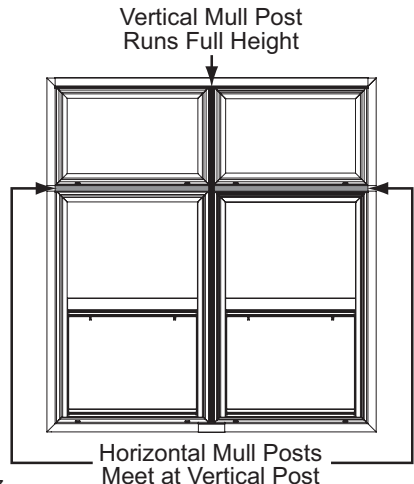



**Measuring for Mull Clips and Mull Posts**

**Horizontal Mull Pieces**

1. Lay units on a clean flat surface, exterior facing up, with the adjacent nail fins removed as previously instructed, and arranged as they will be installed.
2. Slide units tightly together so they touch.
3. Record all measurements.
4. For a Single Mull or Stack (**FIGURES 1 & 2, Page 7**) measure across the exterior accessory grooves see (**FIGURES 1 & 2, below**).

FIGURE 1

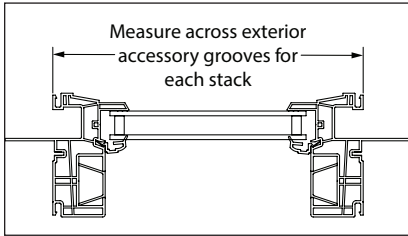
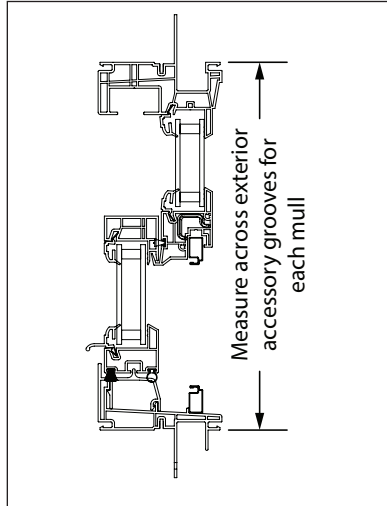

FIGURE 2



5. For a 3-Way Mull Stack Combination (**FIGURE 3, Page 7**) measure height as shown in (**FIGURE 2, right**). For width, measure across the top unit as in (**FIGURE 1, above**).
6. For a 4-Way Mull Stack Combination (**FIGURE 4, Page 7**) measure height the full length of the combined units and **add 1/2"**. For width, measure width of each unit, across the exterior accessory grooves, as in (**FIGURE 1, above**).
7. Cut the mull clips and mull posts to length.

FIGURE 3

**C-Mull Clip**



FIGURE 4

**T-Mull Post**

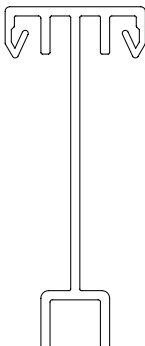

The smaller mull clip (**FIGURE 3**) is applied on the interior and the mull post (**FIGURE 4**) is installed from the exterior.

Follow the correct procedures as explained in the following sections.

Mull Clip Installation – Interior

FIGURE 1

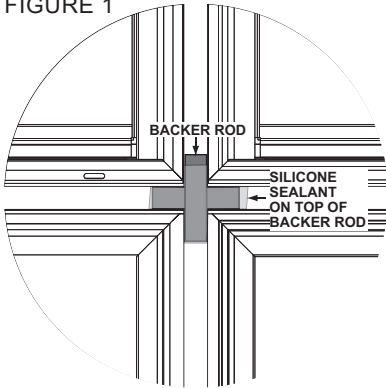

FIGURE 2

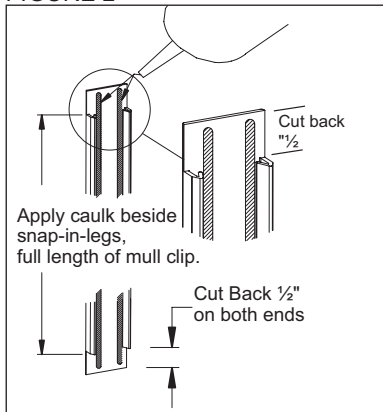
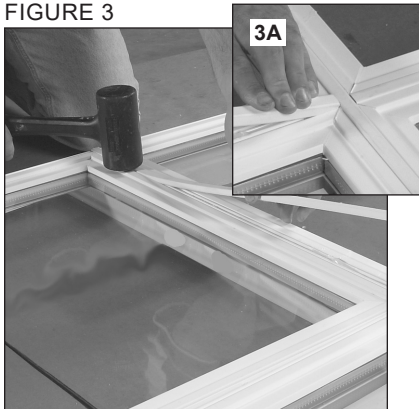

FIGURE 3



1. Place units on a clean, flat, protected surface with the interior facing up. Arrange units as they will be installed. Use 1/2" plywood spacer blocks to set units a uniform 1/2" apart.

**⚠ IMPORTANT:** Use a straightedge or level to align units so they are square, straight, and even with each other.

2. For a 3 or 4-Way assembly, insert 5" long, 1/2" diameter caulk backer rod into the gap where the units meet (FIGURE 1). Push backer rod down so there is at least 1/4" space above the rod. Fill this 1/4" space with silicone sealant applied over the backer rod (FIGURE 1).
3. Using a utility knife, rotary tool, or end nipper pliers, cut the snap-in-legs back 1/2" on each end of the mull clip (FIGURE 2).
4. Apply a minimum 1/4" continuous bead of caulk the full length of each mull clip, along the side of each snap-in-leg before installing the clip (FIGURE 2).

**NOTE:** If mulling and stacking, install the vertical mull clip first. Then install the horizontal mull clip(s).

5. Be sure units are still aligned with each other and then start the mull clip into one end of the accessory groove. With a rubber mallet (FIGURE 3), lightly tap so the clip snaps into the accessory grooves on both units (FIGURE 3A). Ensure that the mull clip has fully snapped into place along the unit's entire length. If needed, use a wood block and rubber mallet to tap mull clips tightly into place.
6. The shorter mull clips must fit tight against the longer clips at their intersection (FIGURES 3 & 3A).
7. After installing all the interior mull clips, remove excess caulk with denatured alcohol and clean soft rags.

## Mull Post Installation – Exterior

### 3-Way Mull/Stack Combinations

The horizontal mull post installs first and runs the full width of the unit (**FIGURE 1**). The vertical mull post fits tight against the horizontal mull post and runs to the bottom of the units.

FIGURE 1

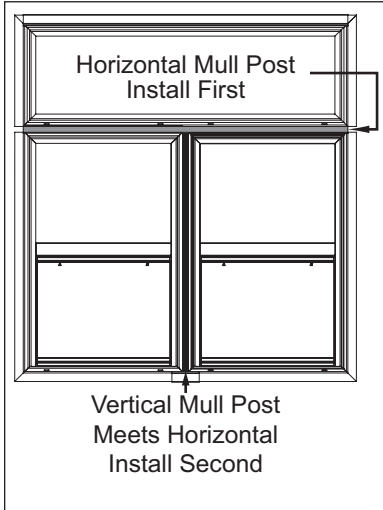

### 4-Way Mull Combination

The vertical mull post is installed first (**FIGURE 2**) and must run the full height of the units. The horizontal mull posts are cut to the width of each individual window unit (**FIGURE 2**).

FIGURE 2

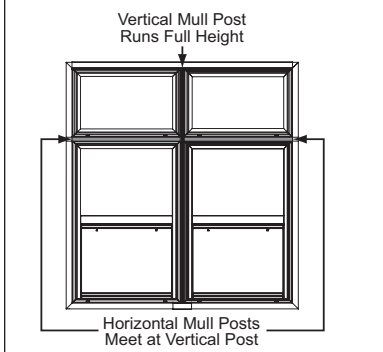

**⚠ IMPORTANT:** Use an adequate number of people, clamps, and supports to prevent units from separating.

1. Turn units over so the exterior side is facing up on a flat, clean, uniformly supporting surface.
2. Check length of mull posts, cut in Step 7 Page 8, against the the window units. Adjust lengths as needed.

### Mull Post Preparation

3. Cut back the snap-in-legs by 1/2" on each end of the mull post (**FIGURE 3**).
4. Cut back the mull post body by 1/8" on each end (**FIGURE 3**).

FIGURE 3

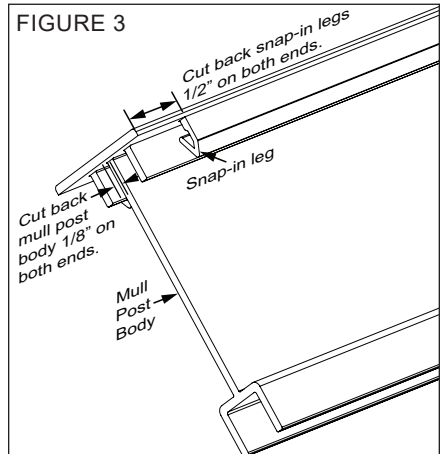

## Mull Post Installation – Exterior (cont.)

For a 1-Way Mull or Stack the mull post runs the full length of the unit(s).

### For a 3 or 4-Way Assembly:

The shorter mull posts, that meet the full-length mull post, must have the ends that join with the full-length post prepared prior to installation. The preparation is necessary to ensure a weather-tight seal at the joint. **The full-length mull post is installed first.**

- For the full-length mull post, apply a minimum 1/4" continuous silicone bead the full length, along the snap-in legs on each side of each mull post before installing (**FIGURE 4**).
- Place a caulked mull post between the units and align one end flush with top or bottom of window frame.

FIGURE 4

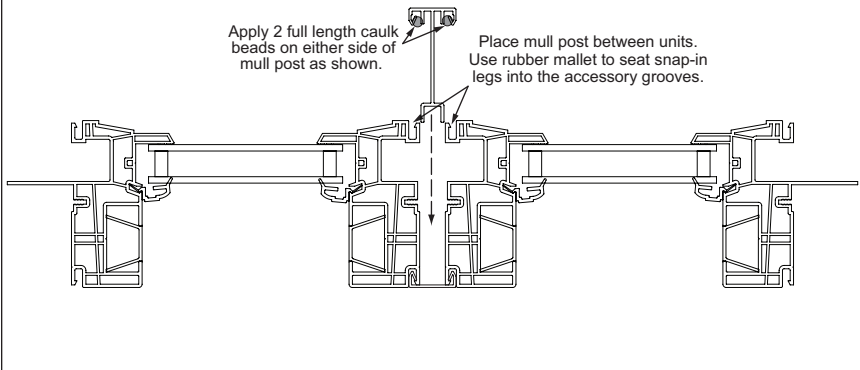

- Start one end of the mull post into the accessory grooves. Tap along the mull post to seat the snap-in-legs into both units (**FIGURE 5**). Ensure mull posts are fully snapped into place along the unit's entire length. If necessary, use a wood block and rubber mallet to tap mull posts tightly into place. Repeat for all full-length mull posts.

FIGURE 5



**Mull Post Installation – Exterior (cont.)**

**For a 3 or 4-Way Assembly:**

8. Apply silicone to both sides of the full length mull post where it will contact the shorter mull posts within the mull pocket, this will help to ensure a good seal to the mull joints (**FIGURE 6**).
9. Apply sealant to snap-in-legs of shorter mull posts and to exterior accessory grooves (see Step 5 on opposing page). Place shorter mull post into the space between the units, press the end into the sealant applied in step 8. Butt the shorter mull post tightly against the full-length post and tap the snap-in-legs down into the exterior accessory grooves. Ensure mull posts are fully snapped into place. If necessary, use a wood block and rubber mallet to tap mull posts tightly into place. Repeat for all short mull posts.
10. Remove excess silicone with clean soft rags and denatured alcohol.

FIGURE 6

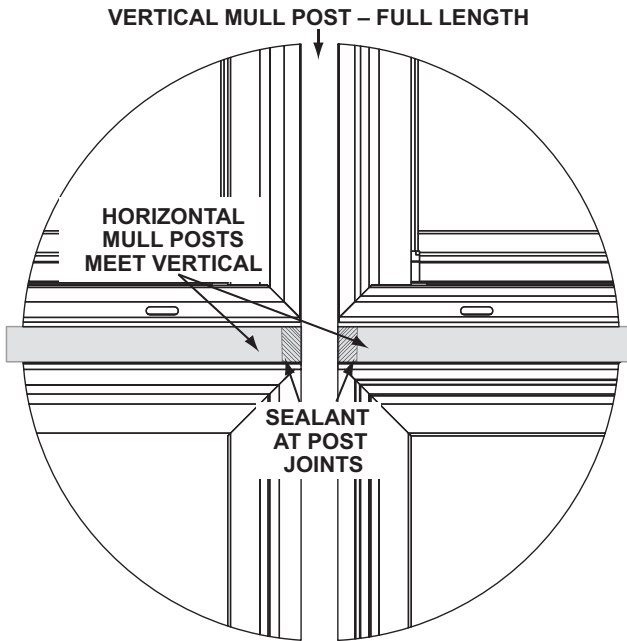

**Mull Post Installation – Exterior (cont.)**

**Fill Gap Between Units**

11. There will be a hollow in the mull pocket on either side of the post at the head, and sill on mullied units and at side jambs on stacked units (**FIGURES 7 & 7A**).
12. Push foam backer rods into each mull pocket hollow leaving 1/4" space above the backer rod (**FIGURES 7A & 8**).
13. Completely fill area above the backer rod with silicone (**FIGURE 9**).

FIGURE 7

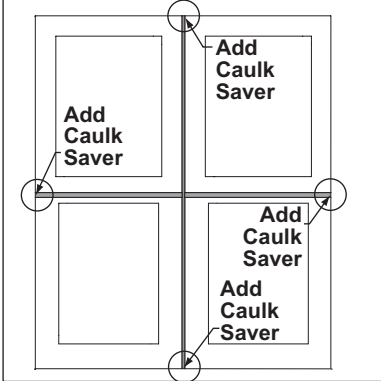

FIGURE 7A

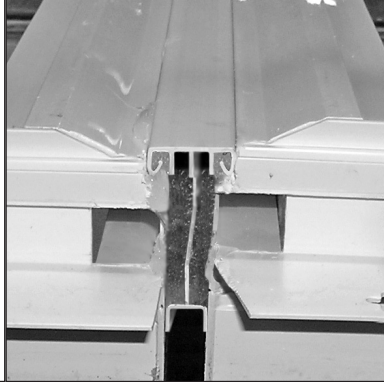

FIGURE 8

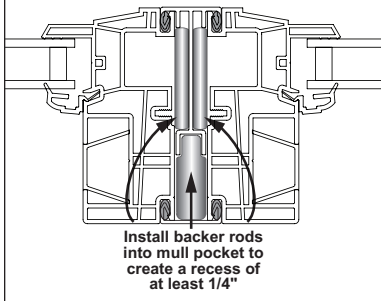
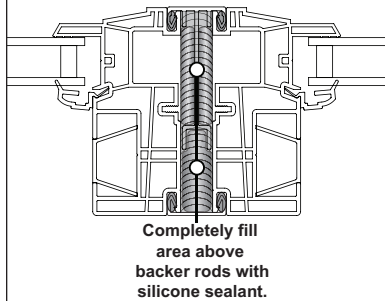

FIGURE 9



14. After sealant application, attach a self-adhesive gasket to the interior side of the nailing fin and frame to cover the mull gap (**FIGURES 10 & 11**).

FIGURE 10



FIGURE 11



## ALL-VINYL WINDOW – MULL, STACK OR MULL & STACK

### Apply Joining Plates

FIGURE 1

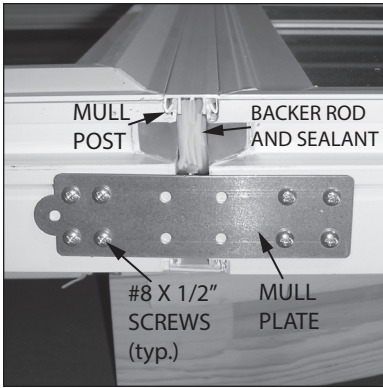

1. Use a level or straightedge to check that units are still aligned with each other. They must be square, even, and straight. Make necessary adjustments.

2. After mull clips & mull posts are installed, caulked, and gaskets applied, install a joining plate over each stacked and/or mull joint (FIGURE 1).

**NOTE:** Be sure backer rod, caulk, and gaskets are applied before installing joining plates.

3. Align plate so it straddles the joint and attach with at least eight screws, four on each side of mull or stack joint. Use #8 x 1/2" Phillips, pan head stainless steel sheet metal screws (FIGURE 1).

### Install Plumb Plates – Optional Procedure

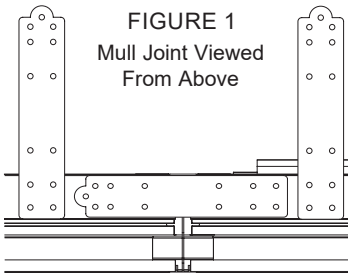

To help plumb the window while installing, attach additional joining plates on each side of each mull (top and bottom) or stack joint (both sides) (FIGURES 1 & 2).

These plates will help you attain a more accurate alignment of the units with the rough opening.

After the window is installed the plates are bent at a right angle and fastened to the framing members.

FIGURE 2

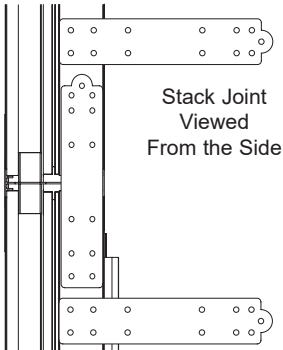

## Install Head Drip Cap

**⚠ IMPORTANT:** Head drip cap runs full width of mull(s).

**NOTE:** There is a separate drip cap for J-Channel windows and those with the optional J-Channel filler. Be sure your drip cap is the proper type (**FIGURE 1**).

FIGURE 1

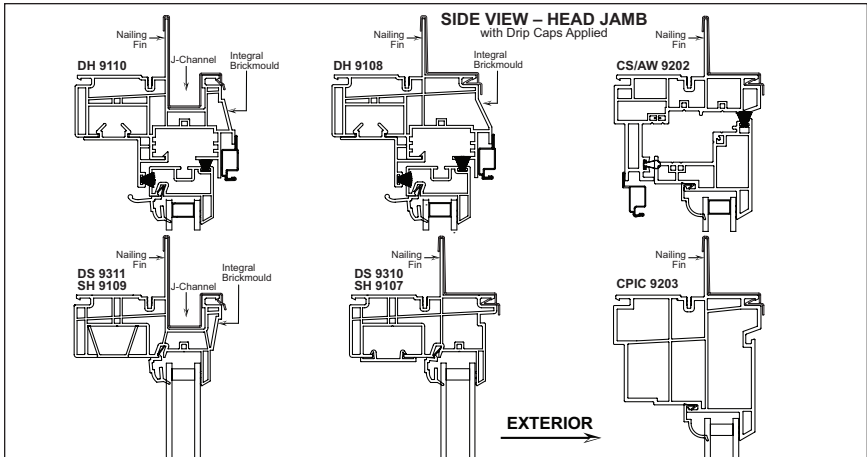

1. Measure overall width of mull(s) assembly across outside edges of integral brickmould.
2. Cut a vinyl drip cap to this length.

**⚠ IMPORTANT:** Be sure accessory grooves at mull joint are opened. See Page 6 Step 4.

3. Trim excess weld build-up at the frame corners on the top of the units.
4. Caulk mull joints at the top of each window frame (**FIGURE 2**). Caulk top of window frames for full length of mull(s) assembly and at each end of head jamb (**FIGURE 3**).

FIGURE 2

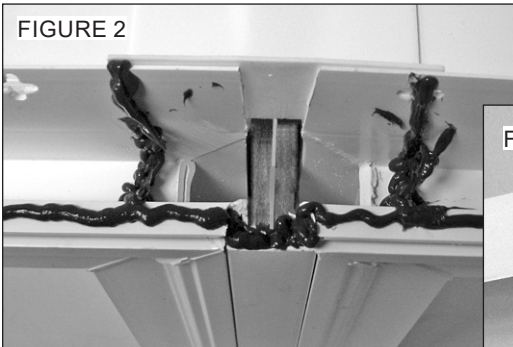
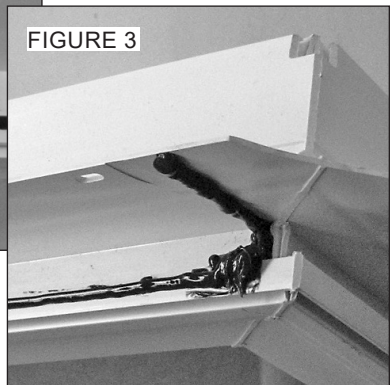

FIGURE 3





Install Head Drip Cap (cont.)

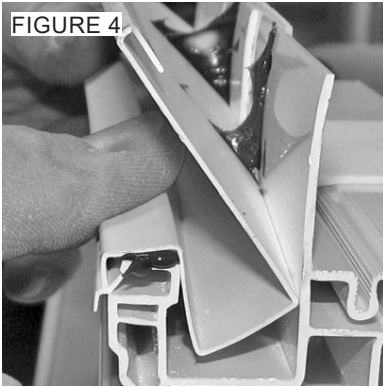

FIGURE 4

5. Center drip cap on the width of the combined unit and place the edge of the snap-in-leg into the exterior accessory groove (**FIGURE 4**).
6. Work along width of unit, pulling drip cap up and over nailing fin (**FIGURE 5**) while firmly pushing the drip cap down into the J-Channel pocket (**FIGURE 6**) as needed. Ensure snap-in-leg fully seats in exterior accessory groove along drip cap's full length.

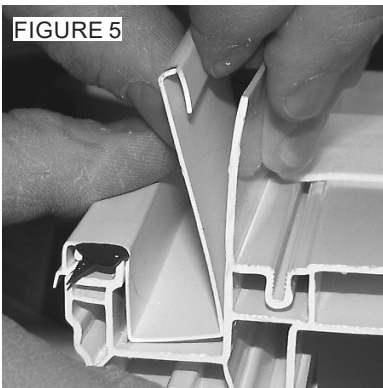

FIGURE 5

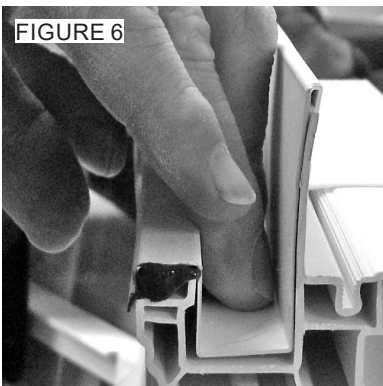
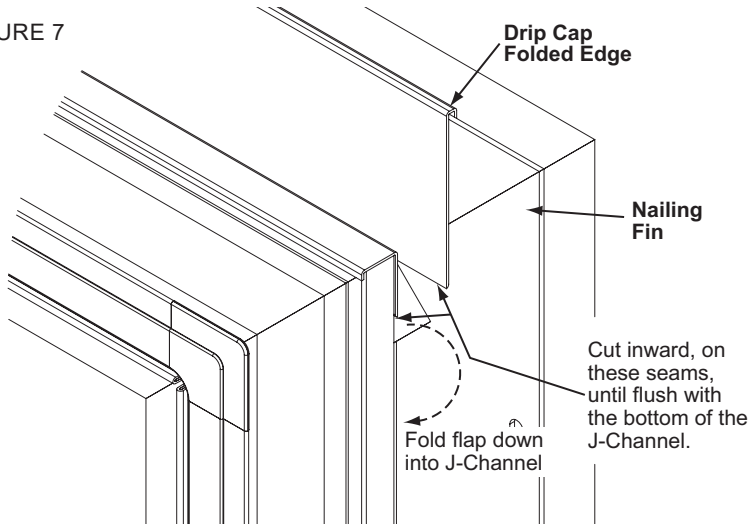

FIGURE 6

Install Head Drip Cap (cont.)

FIGURE 7



Step 7 Only Needed for Units with J-Channel

7. Cut the drip cap, only the part extending beyond the head J-Channel pocket, inward along its seams as shown in (FIGURE 7) and fold the resulting flap down into the J-Channel pocket. This allows for siding to be placed into the J-Channel.
8. Use a shop towel dampened with denatured alcohol to clean-off all excess silicone.



**IMPORTANT:** Allow the caulk to set up before handling, moving, or installing the assembled unit.

**Seal Side and Sill Joints**

1. Cut a 6" long piece of drip cap for the sill and/or sides. See Page 5 to select the right shaped drip cap. Notch snap-in leg at center of drip cap to provide clearance for the mull post or mull clip (**FIGURE 1**).
2. Caulk the exterior as shown below in (**FIGURE 2**). Caulk the sill joint on a mullied unit and the sides on a stacked unit.
3. Install drip caps as appropriate for your assembly.

FIGURE 1

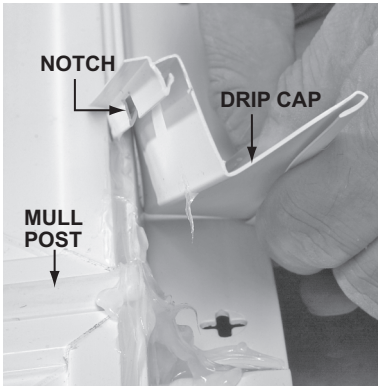

FIGURE 2A – ONE SIDE OF A STACKED UNIT



FIGURE 2B – ONE SIDE OF A STACKED UNIT COMPLETED. SILL WOULD BE SIMILAR



Mull or mull and stack assembly is now complete.

Allow caulk to set up before installing window.

To install the "new" mullied or stacked unit, follow installation instructions packed with one of the individual windows.

