

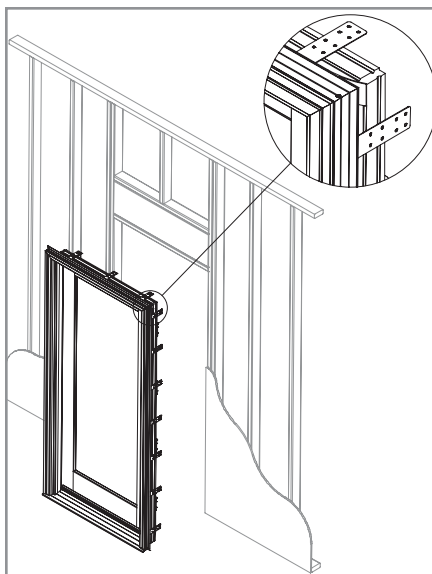

# Installation Supplement For All Window and Door Products Utilizing Interior Installation Clips

*This document must be used in conjunction with the installation instructions packed with your specific window or door unit*

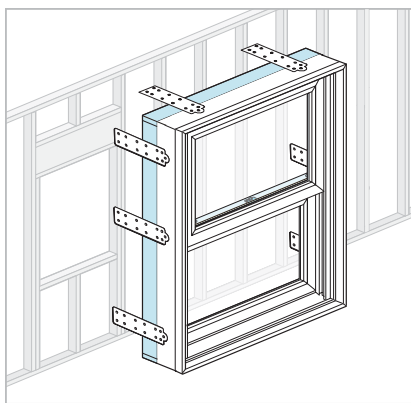

**IMPORTANT:** Please read this supplement and your unit installation instructions before you begin.

**IMPORTANT:** Thoroughly read and follow these instructions. Failure to install as recommended will void any warranty, expressed or implied. Check building codes for the area in which the windows or doors are being installed before installation to ensure proper compliance. The following instructions are based on typical frame construction. Specific applications may differ. The window and door manufacturer recommends that you consult a qualified installation professional. The window and door manufacturer is not responsible for installation.

**CAUTION** These instructions, Part No. 1037024, supplement the standard installation instructions shipped with your unit and are to be used only for units equipped with Interior Installation Clips (**FIGURE 1 & 2**).

FIGURE 1

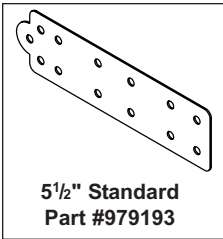
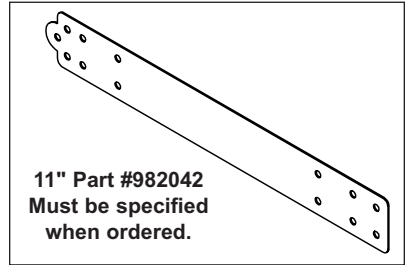

FIGURE 2



**Tools Required:**

- Phillips Screwdriver
- Standard Screwdriver
- Hammer
- Caulk Gun
- Level
- Hacksaw
- Measuring Tape
- Putty Knife
- Rubber Mallet
- Utility Knife
- Electric Drill and 1/8" Drill Bit
- Tin Snips
- Pry Bar

**NOTE:** When fasteners are exposed to a corrosive environment, such as a sea coast location, stainless steel fasteners must be used.

**Materials Required:**

- Weather Barrier Self-Adhering Tape
  - Paint, Stain and Accessories
  - Gloves
  - Safety Glasses
  - 2-3" Galvanized Roofing Nails (To penetrate framing material by at least 1-1/2")
  - High-Quality, Clear, Exterior, Neutral-Cure, Silicone Caulk
  - Shims
  - #6 x 1/2" Stainless Steel, Pan Head Sheet Metal Screws\*
  - #6 x 1-1/2" Stainless Steel, Pan Head Sheet Metal Screws\*
  - #10 x 3" Stainless Steel, Flat Head Screws\* (for doors only)
  - 8D (2") Galvanized Box Nails\*
  - Window or Door Equipped With Installation Clips and/or a Separate Set of Clips\*
- \*Quantity depends on unit width and height.



Recognize this symbol. This is the Safety-Alert symbol. When you see this symbol be alert to the potential for personal injury or product damage.



### **DANGER**

Falling from window openings may result in severe injury or death. **DO NOT** leave openings unattended when children are present.



### **WARNING**

Wear gloves, safety glasses, goggles or eye-shields appropriate to the procedure.



### **DANGER**



Screen will not stop children, any one or anything from falling out window.

Keep children and objects away from open window.



### **WARNING**

Weight of window and door unit(s) and accessories will vary. Use a reasonable number of people with sufficient strength to lift, carry and install window or door unit(s) and accessories. Always consider site conditions and use appropriate techniques when installing.



### **WARNING**

Improper use of hand and power tools could result in personal injury and/or product damage. Follow equipment manufacturers' instructions for safe operation. Always wear safety glasses.

High-quality, exterior, neutral-cure, clear, silicone sealant (compatible with window and door materials and the exterior face of the wall) is to be used for all procedures in the following instructions which call for caulking or sealant.



### **DANGER**



### **CUT HAZARD**

•May cause serious injuries if broken.

## **SAFETY INSTRUCTIONS**

Read installation instructions completely before beginning procedure.

**Rough opening preparation is fully explained in the separate installation instructions packed with your window or door unit.**

**Rough opening preparation can vary based on unit options. You must complete all applicable rough opening preparation steps, as stated in the installation instructions for your unit, before using this supplement to install your window or door unit.**

## Before You Begin

**⚠ IMPORTANT:** When accessories have been ordered, apply according to the directions **BEFORE** you install the unit OR prep the rough opening.

FIGURE 1

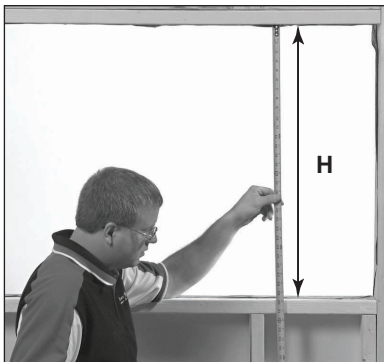

FIGURE 2

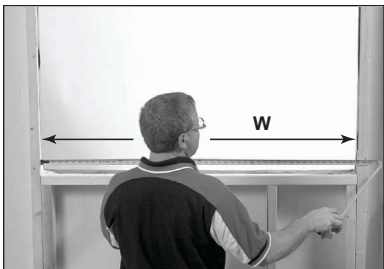
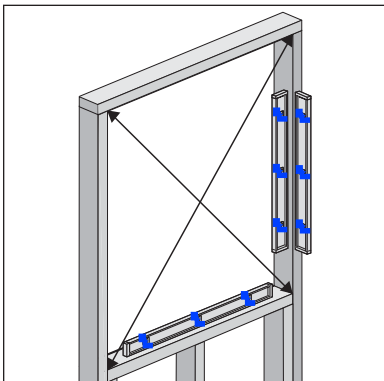

FIGURE 3



**⚠ IMPORTANT:** Perform the following **BEFORE** starting installation. Make sure you have:

- The correct product type (casement, tilt, hinged door, etc.)
- The correct size unit (Width and Height) for your rough opening (FIGURES 1 & 2).
- Perform a complete unit inspection checking for shipping damage, broken glass, or other physical damage. Fix whatever is wrong before installation or start appropriate claim procedures.
- When accessories such as jamb extension have been ordered, apply according to the directions **BEFORE** you install the unit OR prep the rough opening.

1. Measure the rough opening to ensure that it is NOT more than:

**FOR ALL-VINYL PRODUCTS –**

3/4" wider in overall Width or 3/4" taller in overall Height than outside width or height of your entire unit frame assembly.

**FOR WOOD and CLAD PRODUCTS**

1" wider in overall Width or 1" taller in overall Height than outside width or height of your entire unit frame assembly.

If these guidelines are not met, add furring to reduce the RO to the above maximum allowances.

Furring material must be solid, continuous, and run the full height and/or width of the rough opening. Furring material depth must be at least equal to window jamb depth. Furring material must be securely fastened to the rough opening framing.

2. Make sure walls are plumb and not twisted. Check rough opening for squareness by measuring diagonally from corner to corner in both directions. Diagonal measurements cannot differ from each other by more than 1/4" (FIGURE 3).

**⚠ IMPORTANT:** Fix problems with plumb, level or squareness before proceeding.



## Before Installing – Windows & Doors

FIGURE 1

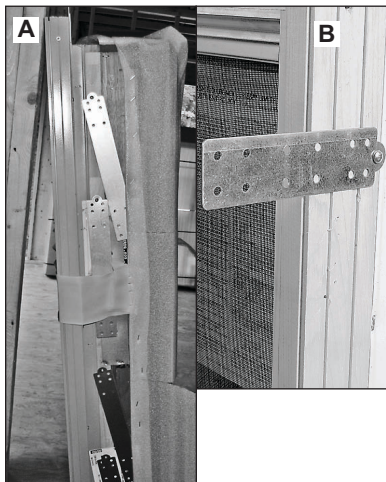

1. If installation clips were requested with the order, they should be attached and hanging on the jambs (**FIGURE 1A**). Loosen the fastener (do not remove) holding clips in place. Rotate the clips 90° (**FIGURE 1B**) and secure to the jamb with four #6 x 1/2" [13mm] pan head stainless steel sheet metal screws.

**⚠ IMPORTANT:** Do not apply clips at the sill.

**NOTE:** If installation clips were shipped loose, place a clip 4" from each corner (**FIGURE 2**). Locate remaining clips 12-16" apart all the way around the unit. Make sure the clips are perpendicular to the unit.

Locate the clips on the jambs to allow 1-1/2" to 2" of clip to extend beyond the interior surface of the jamb.

FIGURE 2

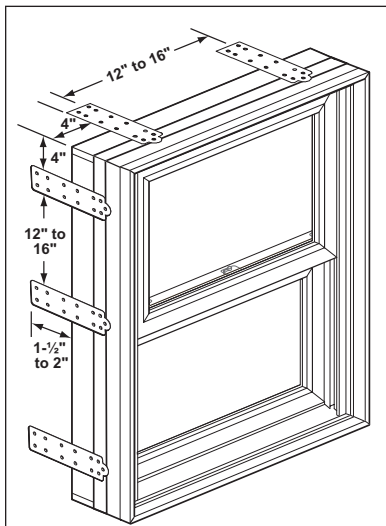

Secure each clip to the jamb with four #6 x 1/2" [13mm] stainless steel pan head sheet metal screws. Attach clips before the unit is placed in the rough opening.

**⚠ IMPORTANT:** When accessories such as jamb extension, or drywall return have been ordered, apply according to the directions included with your unit **BEFORE** you install the unit **OR** prep the rough opening.

**Before installing, make sure sash is closed and locked.**

**Remove all shipping and packing from the unit.**

**Do not remove any clips holding door panels closed until after installation is completed.**

**Check the unit's installation instructions for specific steps when exterior casing trim is applied.**

## Before Installing – Doors

FIGURE 1

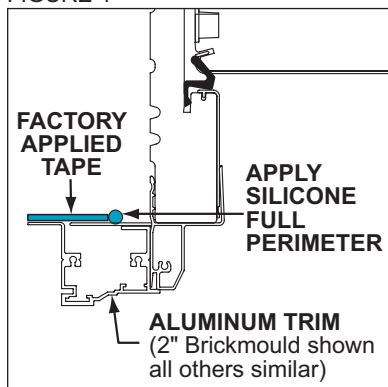

### For Door Units

1. For units with aluminum exterior trim, peel back release liner on the back of the black tape that can be found on the back side of your exterior trim. Apply an additional silicone bead around the full perimeter as shown in (FIGURE 1). This bead of silicone should be right on the line where the tape starts. Make sure the silicone bead will seal against the exterior wall surface.

*Also see "Door Installation Diagram" on Page 7.*

## Installation

FIGURE 1



1. After all clips are securely attached, and the rough opening is prepared according to the unit's installation instructions, apply silicone sealant as directed in the unit's installation instructions.
2. Place unit into the rough opening and center it. Level unit on the interior or exterior across the sill and head (FIGURE 2). If necessary to level unit, place shims directly below the side jamba. While holding unit in place, square and plumb jamba from the interior or exterior. Check both side-to-side and inside-to-outside. Measure unit from corner-to-corner to check for square. To plumb, level and square, use a pry bar to shift unit and shim as needed.

FIGURE 2



## Installation (cont.)

FIGURE 3

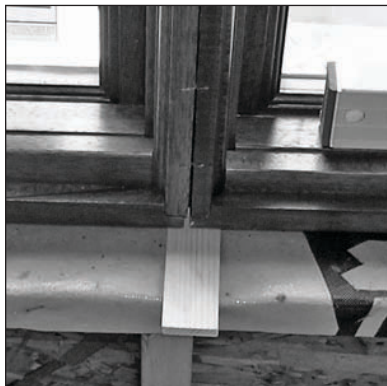

FIGURE 4

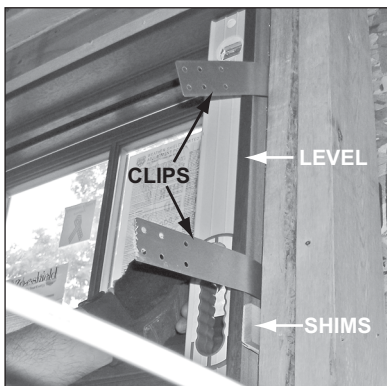

FIGURE 5



**⚠ IMPORTANT:** Muller units must be supported with shims at the sill under each mull joint (FIGURE 3).

**⚠ IMPORTANT:** You must place shims near each clip at the jambs to prevent jamb from twisting as clips are bent into final position (FIGURE 4).

- Starting at a corner of the unit, bend the clip towards the framing material and secure clip to the framing using four #6 stainless steel pan head sheet metal screws or galvanized nails long enough to penetrate framing by at least 1-1/2" (FIGURE 5).

**⚠ CAUTION** Do not fasten through pre-finished brickmould or casing. Do not fasten through aluminum or vinyl exterior.

- Check level and plumb. Fasten the opposite corner in the same manner as the first corner. Check and maintain level, plumb, and square as you continue around the unit securing each clip with four #6 pan head stainless steel metal screws or galvanized nails.

### Additional Steps for Doors

- Install all additional installation screws as called for in the unit's installation instructions.
- Remove weatherstrip in head and side jambs and install #10 x 3" long stainless steel flat head screws behind the jamb weatherstrip as shown in (FIGURE 6). Place screws 8" from the corners and 12" to 18" on center. Install screws in side jambs and at head. . . **NOT AT SILL.** Reinstall jamb weatherstrip.

FIGURE 6

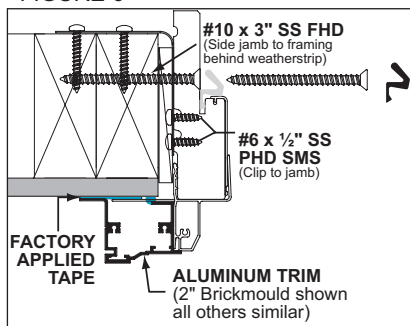

## Square and Straighten the Interior

FIGURE 1

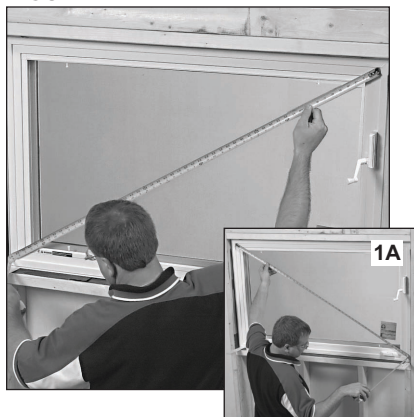

1. Measure the entire unit assembly diagonally in both directions (**FIGURES 1 & 1A**).
2. Shim as needed (**FIGURE 2**) to get the diagonal measurements exactly the same.

Using a level as a straightedge, place shims between the frame and the rough opening to straighten the side jamb and sill (**FIGURE 2**).

### For Doors

Follow steps in the unit installation instructions to adjust level, plumb, and square and to adjust doors for proper alignment, reveal and operation.

## Insulate and Trim

1. Loosely insulate between the unit's frame and rough opening with fiberglass.

**⚠ IMPORTANT:** Do not over pack insulation.

OR

You can use minimal expansion foam products specifically designated and certified as meeting ASTM and AAMA requirements for "door or window use" to fill the shim space between the unit's frame and the rough opening. Foam manufacturer's installation and curing instructions must be followed.

**⚠ IMPORTANT:** Rigid metal drip cap must be installed on wood brickmould units. See instructions on the following page.

Installation is ready for interior wall finish and trim.

FIGURE 2



## Install Drip Cap Over Brickmould

FIGURE 1

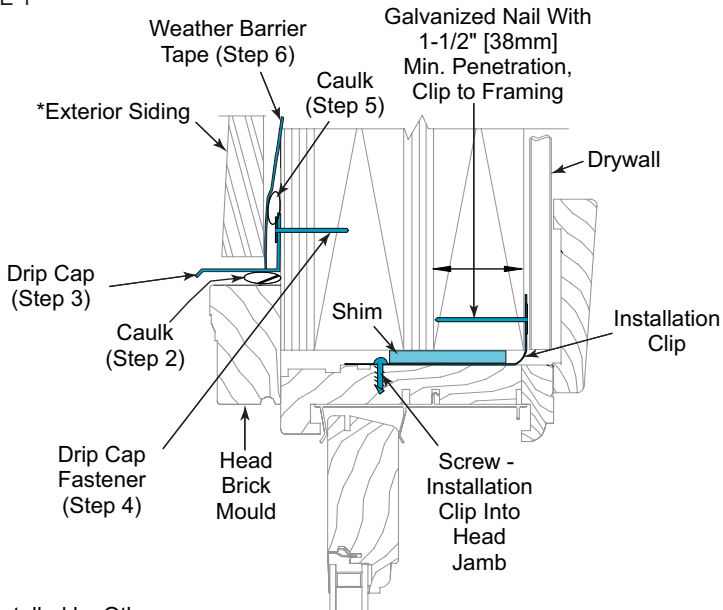

\*Installed by Others

NOTE: Gaps between components in illustration are for clarity only.  
Normal caulking and installation practices must be followed.

### Install Drip Cap (FIGURE 1)

1. Cut a piece of rigid metal drip cap 1" [26mm] longer than the head brickmould width.
2. Apply a continuous bead of caulk, horizontally, on the top surface of the head brickmould.
3. Seat drip cap on head brickmould and center the cap so there is 1/2" [13mm] overhang on both ends.
4. Fasten the rigid metal drip cap to the sheathing with galvanized roofing nails long enough to penetrate the framing members by 1-1/2" [38mm].
5. Apply a continuous bead of caulk along the length of the joint between the drip cap and sheathing.
6. Apply a piece of high-quality weather barrier self-adhering tape or equivalent, to the sheathing, covering the entire face of the rigid metal drip cap. Weather barrier tape must be long enough to extend 4" [102mm] past the window's width on both sides. Cover the drip cap fastener holes completely. Use a rubber roller to apply.

## Door Installation Diagram

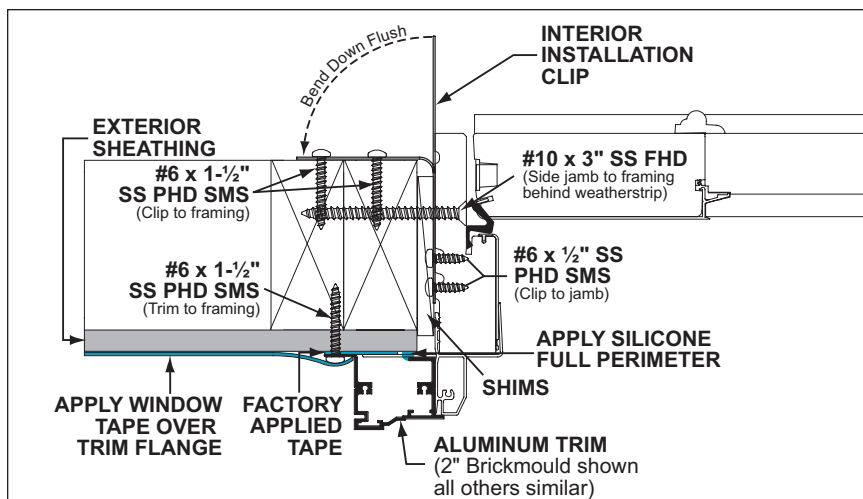

## Products With Synthetic Stucco

Serious concerns have been raised about excessive moisture problems in homes and other buildings that have Exterior Insulation Finish Systems, commonly referred to as EIFS or Synthetic Stucco.

Many experts agree that a certain amount of water or moisture can be expected to enter almost any building exterior system. The building system should allow such water and moisture to escape or "weep" to the exterior, so no damage occurs. However, some EIFS systems may not allow water or moisture that penetrates the wall system to "weep" to the exterior. This can cause excessive moisture to accumulate within the wall system, which can cause serious damage to wall and other building components. It has been reported that so-called "barrier" EIFS systems are particularly prone to this problem.

Moisture problems in any type of building structure can be reduced by proper design and construction with appropriate moisture control considerations, taking into account prevailing climate conditions. Examples of moisture control considerations include flashing and/or sealing of all building exterior penetration points, use of appropriate materials and construction techniques, adherence to applicable building codes, and general attention to proper design and workmanship of the entire building system, including allowances for management of moisture within the wall system.

Determination of proper building design, components and construction, including moisture management, are the responsibility of the design architect, the contractors, and the manufacturer of the exterior wall finish products. Questions and concerns about moisture management issues should be taken up with these professionals. The window manufacturer is not responsible for problems or damages caused by deficiencies in building design, construction or maintenance, failure to install our products properly, or use of our products in systems that do not allow for proper management of moisture within the wall system.

## Recommended Finishing Instructions



### WARNING

Always follow chemical manufacturers' safety instructions when using chemicals to avoid injury or illness.

Vinyl and aluminum may be cleaned with mild soap and water. Hard to remove stains and mineral deposits may be removed with mineral spirits. Factory-applied painted surfaces can be cleaned with mild household detergents and water.

- Do **NOT** clean any surface with gasoline, diesel fuel, solvent based, or petroleum based products.
- Do **NOT** use abrasive materials or strong acidic solutions against vinyl, aluminum, glass, or factory-applied finishes.
- Do **NOT** scrape or use tools that might damage the surface.
- Do **NOT** paint vinyl or aluminum surfaces.
- Do **NOT** use mastic-type tapes such as Duct Tape®.

**NOTE:** If masking tape is used on any surface to aid in painting or staining, remove tape as soon as possible after use. Tape must be removed within 24 hours of application.

For long term use, such as stucco applications; use tape that will release, even when exposed to high temperatures for an extended period of time. (Examples include 3M #2080 and #2090 tapes.)

#### For Bare Wood Surfaces

For best results, we recommend sealing your wood products immediately upon receipt. Avoid storing products or leaving them unfinished for more than 30 days.

1. Remove all construction and adhesive label residue with mineral spirits before finishing.
2. Lightly sand surfaces being finished with 180 grit or finer sandpaper. Be careful not to scratch the glass.
3. After sanding, clean-off sanding dust using lacquer thinner applied to a cloth so the cloth is slightly damp. Let surface dry completely.

#### -If a painted surface is desired:

- If a wood unit is delivered with factory-applied primer paint, it may be painted without repriming, providing the finish paint coat is applied within six (6) months of unit installation.
- If a factory-primed wood unit requires reprim-

ing contact your customer service representative for help in selecting a primer compatible with the factory applied material.

- Factory-applied Accentials™ color system finishes in standard, designer or custom colors do not require additional painting. For "touch up" paint specifications contact your customer service representative.
1. An unprimed wood unit requires priming. Use high quality acrylic or oil-based primer. Use compatible oil or high quality acrylic finish coats. Refer to the primer and paint manufacturers' instructions.
  2. When priming bare wood or repriming, cover all exposed wood surfaces. Priming all exposed surfaces helps prevent end splitting, warping and/or checking.
  3. Once primed, apply two (2) coats of paint on all exposed wood surfaces.

#### -If a stained surface is desired:



**If no sealer is applied over stain, the wood will weather very rapidly and defects will occur. Apply at least two (2) coats of sealer.**

1. Use only oil-based stain. A gel stain is easier to apply as it does not easily run or drip. The clear top coats may be oil or water-based. Apply at least two top coats of sealer or varnish.
- Stain applied to soft and porous woods such as pine, maple, alder, and fir can result in splotchy or uneven color appearance. Softer areas absorb pigmented stain more readily than harder areas, making the soft spots darker. The uneven absorption is especially prevalent with heavily pigmented darker stains. To determine if your stain choice is heavily pigmented and prone to splotchy application, view the opened and stirred stain container with an indirect light source. If you can see "down into" the stain, it is a lighter pigmented variety. If you cannot see "down into" the stain, it is a heavily pigmented type and will be prone to uneven absorption.

*Continued on the next page.*



## Recommended Finishing Instructions (cont.)

- A pre-stain wood conditioner, applied before staining, will help softer woods absorb stain more evenly. Apply both wood conditioner and desired stain according to the manufacturers' instructions.
  - 2. Apply one (1) coat of sealer to the stained surface and let dry. Use a high-quality, UV stabilized, exterior sealer.
  - 3. Before applying the next finish coat, make sure the previous coat is completely dry. Then lightly sand previous finish coat with 180 grit or finer sandpaper. Clean off all sanding dust and wipe surfaces with a tack cloth.
  - 4. Apply next coat of desired finish to surface and let dry. Apply only one coat at a time.
  - 5. For any additional coats of finish, repeat steps 3 and 4.
- For a clear (natural) finish: Follow Steps 1, 2, and 3 under "Bare Wood" and Steps 2, 3, 4, and 5 under "stained surface".

**⚠ IMPORTANT:** Remove sash for finishing. Apply your choice of sealer (paint or varnish) to all exposed wood components. Do not get sealer on weather strip or into mechanical components (sash lock, tilt latches or sash rollers). Ensure bottom and top of sash are also sealed (FIGURE 1).

**⚠ WARNING** Sealer (paint or varnish) applied to sash **MUST DRY COMPLETELY** before reinstalling sash. If not dry, sash may stick in jamb liners. Also weatherstrip and jamb liners may be damaged.

### Window Sash

All active and removable sash must be removed from the window frame after installation so they can be properly sealed (FIGURE 1).

